

ASSEMBLY INSTRUCTIONS

READ CAREFULLY BEFORE ERECTING AWNING

EXLARGE, SIZE 18FT 19FT

1. Assemble and lay out the frame in its correct position on a protective covering or ground sheet. If it's the first time you have used your awning you will have to fit the pole adjusting screws (In a small pack with the frame)
2. Check the caravan channel is clear then pull the awning through. To avoid soiling the canvas, do not drag the awning over the ground, try to keep the awning on your protective cover. When pulled round into position check that both sides are level with the ground.
3. Now slide your 5 Bracket Pads into a provisional position on the cord which runs adjacent to that in caravan channel.
4. From the inside of the awning put the hooked end of the centre section through the centre semi-circular hole in the canvas. Then locate the hook into the eyelet on the canopy. Now raise the centre leg pole and fit the reduced end into the centre section. Hook the centre roof pole into the bracket pad then extend out into the centre section.
5. Again from the inside put the hooked end of the corner section through their respective semi-circular holes and ensure the hook goes through the eyelet on the canopy. Mount the legs and extend your centre cross pole into place. Hook corner roof poles into bracket pads and extend out into corner sections.
6. Tension up the roof section of the frame using the adjusting screw. Starting with the centre cross poles and then the roof poles.
7. Make sure all your zips are fastened and then level the mud-wall with the ground by adjusting the legs. Now with the supplied pegs, peg the corners nearest the caravan, and then peg the front corners of the awning (**always use the supplied elastics, never peg directly into D ring this will lead to damage**). Now peg the rest of the awning crossing the rubbers at all zip ends.
8. Fit the two extra roof poles evenly spaced between corner and centre roof poles and tension.
9. Fit the wheel strip by sliding into the channel on the lower part of the van and peg down with the small mushroom pegs provided.
10. A wheel arch cover is provided and comes supplied with adhesive fasteners. Firstly stick the loop (fluffy) side to the top corners of the wheel arch cover. Now place the remaining two halves of Velcro squarely onto their opposites, and offer up to van in the desired position and press firmly together. **Do not attempt to separate the Velcro for 24hrs**, this is the curing time for the adhesive.
11. Clip the curtains into the plastic channel sewn above the windows. **Pullman & Executive only**: two long elastics with button ends supplied to keep side curtains against glass (clips between tie backs).

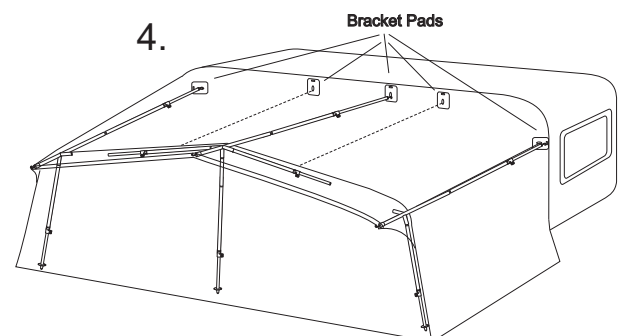
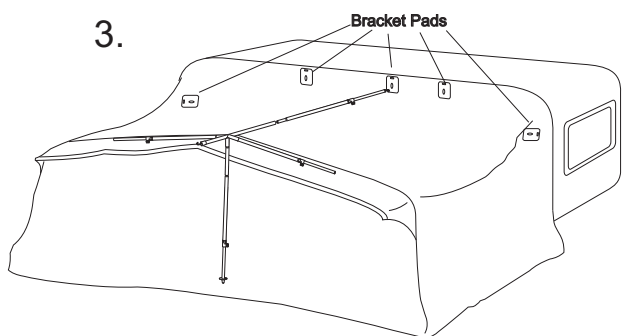
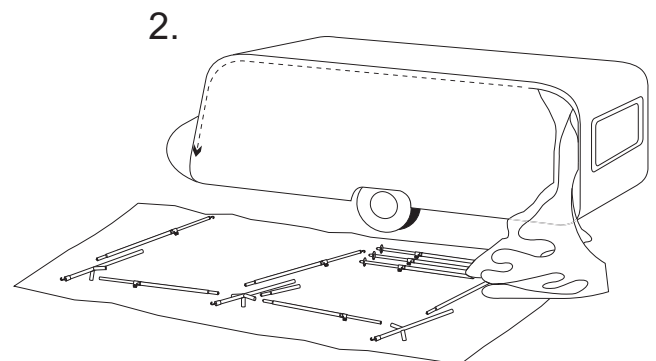
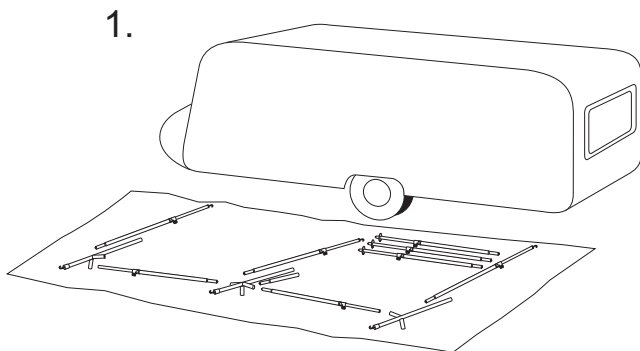

DO'S AND DON'TS

Never pack your awnings away when wet. Occasionally the awning will be removed when wet, this is obviously unavoidable. When this happens, dry out the awning within 24/48 hours.

Never store your awning in a battery box or near acid filled batteries.

The first time you use the awning in wet weather it is possible that seams may leak a little, **DO NOT WORRY** this is not unusual and is part of the weathering process. Once the awning has been wet and dry a couple of times this should cease.

Keep naked flames (eg. Cookers) away from the canvas.

CAUTION

This product is intended solely for use as a caravan awning. NR Components (Todmorden) Ltd will not accept responsibility for accidents, damage or costs incurred resulting from use of this product for any other purpose or from failure to comply with the erection instructions.

NR Components reserves the right to alter specifications without notice at such times, and in such manner they see fit. Minor or major changes may be involved for improvement of the product.